



**SUPPLEMENT 2
TO
SECTIONS 14 & 15

DESIGN SERIES
ELEVATIONS**

SUPPLEMENT - 2

CABINET DESIGN SERIES - CDS

THE FOLLOWING CASEWORK ILLUSTRATIONS ARE ADOPTED AS DESIGN STANDARDS AND PROVIDED TO ASSIST ARCHITECT / DESIGN PROFESSIONALS AND CASEWORK USERS IN SELECTING TYPICAL DESIGNS. THESE ILLUSTRATIONS ARE NOT INTENDED TO LIMIT OR RESTRICT CREATIVITY, OR BE ALL INCLUSIVE.

In utilizing the **CDS** numbering system, it is not necessary to show casework elevations in your architectural drawings. However, it is necessary to show a plan view with each **CDS** number indicated along with the width, height, and depth in inches (Example: "102-36x30x18"). Cabinet dimensions indicate the nominal outside dimension (floor to top of countertop for height and face of finished wall to face of cabinet door for depth). Fabricators are permitted a tolerance of 1/2" plus/minus in width only.

If other designs are desired than those provided for in the **CDS** system, they may be indicated by selecting the **CDS** number most closely representing the desired design, followed by the letter "M" and a description or illustration of the design modification. (Example: "102M - 2 shelves - 36x30x18" or "102M - no shelves - 36x30x18"). If the **CDS** numbering system is used in conjunction with cabinet elevations on architectural drawings, the cabinet elevations shall govern on any conflict between the requirements of the elevation and/or the **CDS** number.

The following casework heights are recommended for various school grades, subject to ADA requirements:

Kindergarten - Grade 1	= 24"
Grades 2 - 3	= 27"
Grades 4 - 6	= 30"
Grades 7 - 9	= 33"
Grades 10 and above	= 36"

The **CABINET DESIGN SERIES** are subdivided as follows:

Base Cabinets w/o Drawers	= 100 Series
Base Cabinets w/ Drawers	= 200 Series
Wall Hung Cabinets	= 300 Series
Tall Storage Cabinets	= 400 Series
Tall Wardrobe Cabinets	= 500 Series
Library Cabinets	= 600 Series
Moveable Cabinets	= 700 Series

ALL HARDWARE AND ACCESSORIES SHALL BE AS APPROVED BY THESE STANDARDS AND LISTED IN THE INSTITUTE'S SEPARATELY PUBLISHED "APPROVED HARDWARE SUPPLEMENT" WHICH IS UPDATED ANNUALLY.

GENERAL NOTES:

- 100 or 200 Series cabinets may be converted into moveable cabinets by prefixing a "7" to the number.
- Moveable cabinets shall be equipped with adequate approved casters for the intended load capacity.
- Cabinet Design Series #'s 728, 729, 735, 736, 737, 738, 739 require metal angle reinforced corners.
- Carts and rolling tall storage cabinets with doors, lacking any horizontal and/or vertical stabilizing dividers, require a diaphragm bottom; specifically Cabinet Design Series #'s 702, 712, 716, 722, 743, 744, 746, 747, 750, and 751.

100 SERIES, BASE CABINETS w/o DRAWERS

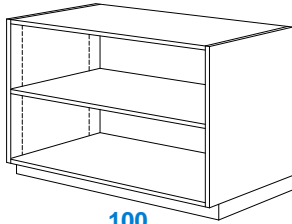

100
Open

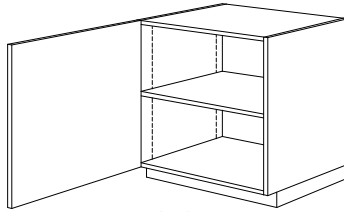

101

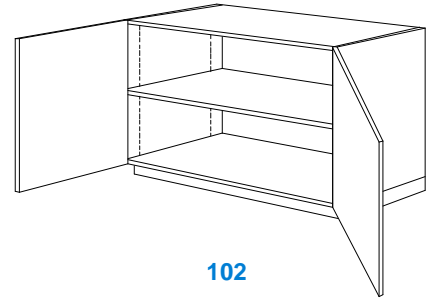

102

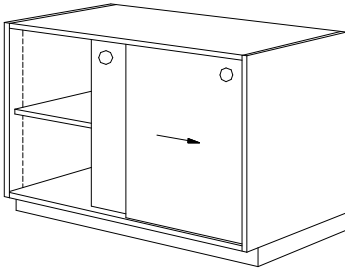

106
3/4" Sliding Doors
without Vertical Divider

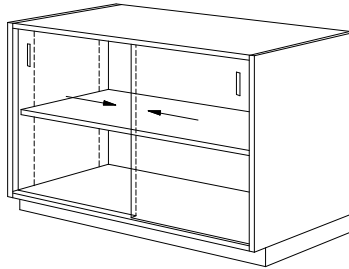

107
1/4" Sliding Glass Doors

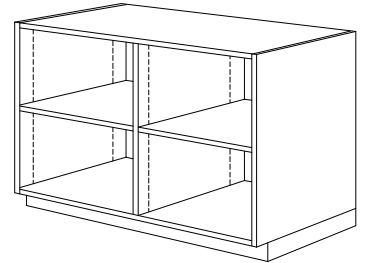

110
Open

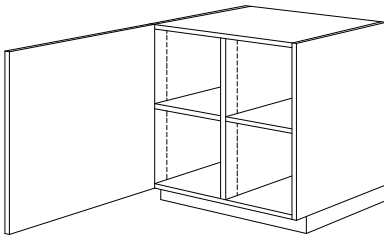

111

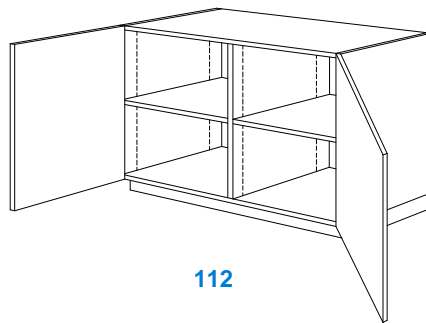

112

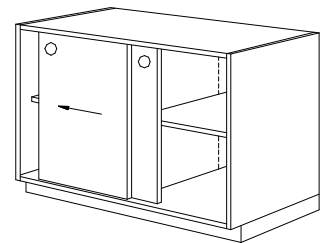

116
3/4" Sliding Doors
with Vertical Divider

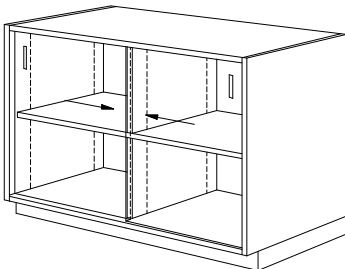

117
1/4" Sliding Glass Doors

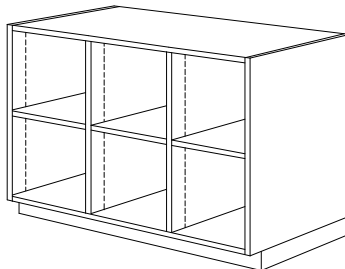

120
Open

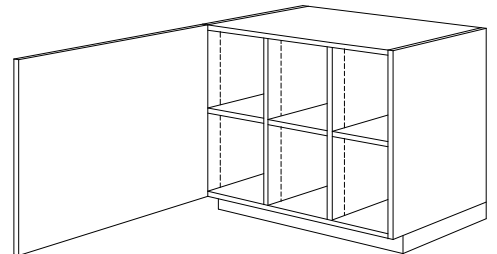

121

NOTE: These drawings are available as **Autodesk® Revit®** Families and **AutoCAD®** ".DWG" and ".DXF" files at <http://www.woodworkinstitute.com/manual.asp> or with our CD Rom version of the **MANUAL**.

100 SERIES, BASE CABINETS w/o DRAWERS

(Continued)

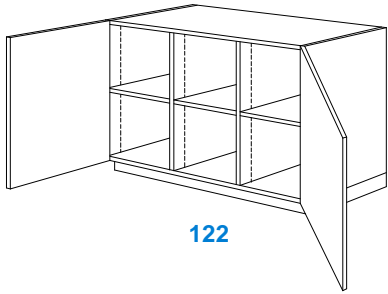

122

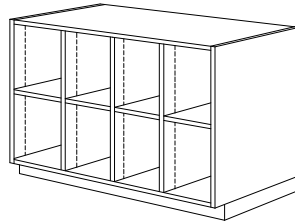

130

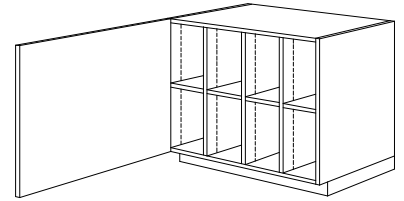

131

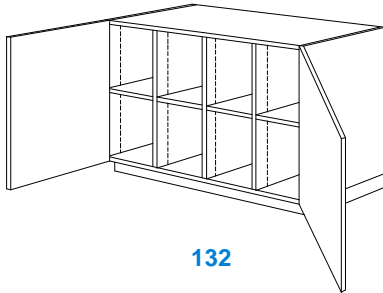

132

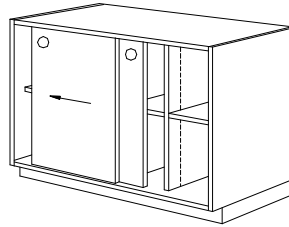

136
3/4" Sliding Doors

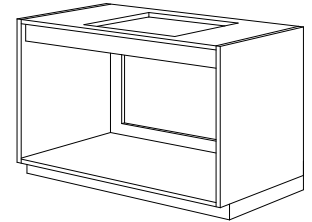

140
Open / Sink
Removable Back
4" Apron

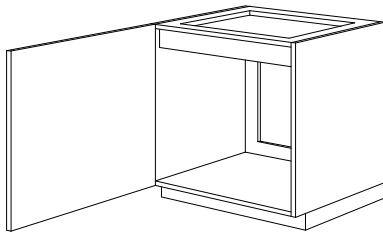

141
Removable Back / Sink
4" Apron Behind Door

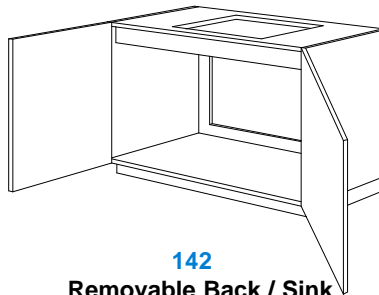

142
Removable Back / Sink
4" Apron Behind Doors

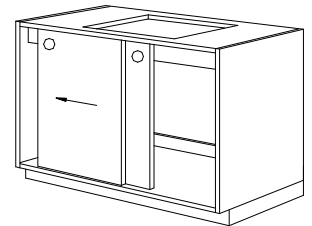

146
Removable Back / Sink
3/4" Sliding Doors
4" Apron Behind Doors

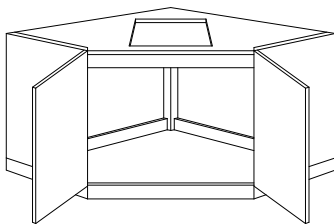

148
Removable Back / Sink
4" Apron Behind Doors

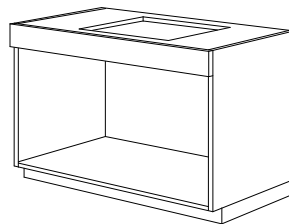

150
Sink / 6" Apron

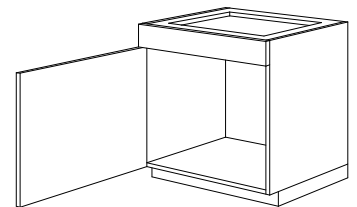

151
Sink / 6" Apron

NOTE: These drawings are available as **Autodesk® Revit®** Families and **AutoCAD®** ".DWG" and ".DXF" files at <http://www.woodworkinstitute.com/manual.asp> or with our CD Rom version of the **MANUAL**.

100 SERIES, BASE CABINETS w/o DRAWERS

(Continued)

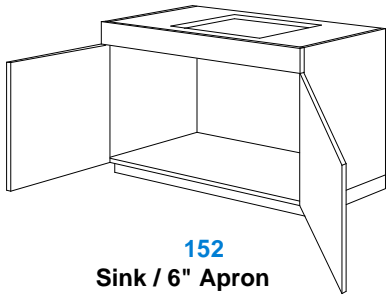

152
Sink / 6" Apron

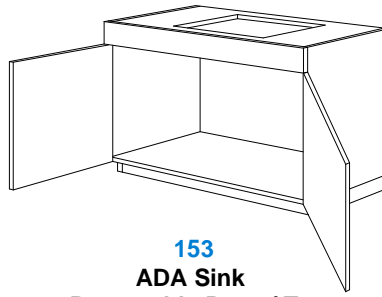

153
ADA Sink
Removable Base / Toe

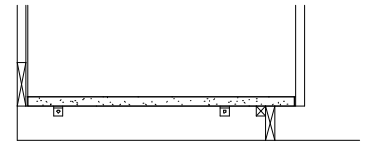

153a
Section Detail of
Removable Base / Toe
Supported on Clips

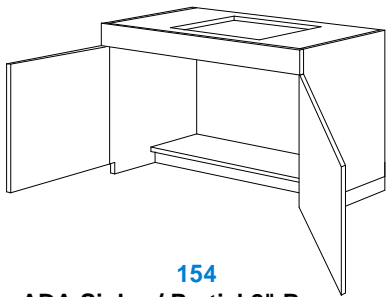

154
ADA Sink w/ Partial 8" Base



154a
Section Detail of
Partial 8" Deep Base

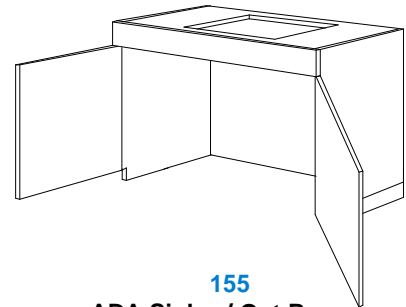

155
ADA Sink w/ Out Base



155a
Section Detail of
No Base

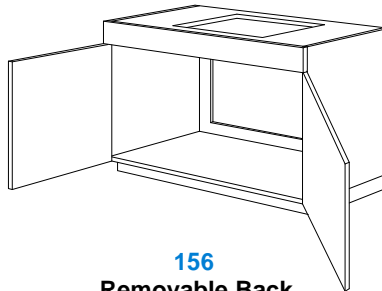

156
Removable Back
Sink / 6" Apron

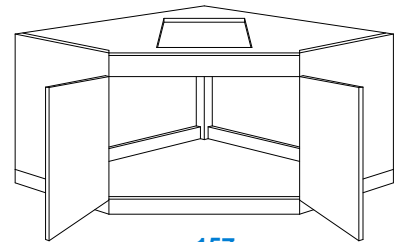

157
Removable Back
Sink / 6" Apron

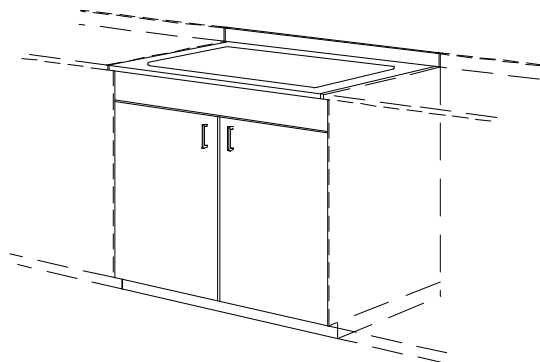

158
ADA Removeable Cabinet Front, Base
and Height Adjustable Countertop

NOTES FOR CABINET 158:

Cabinet doors and sink apron mounted to a removable (for ADA compliance) frame, secured to adjoining wall or cabinets to the left and right.

Base removable for ADA compliance.

Countertop to be self contained with side mounting cleats which can be used to secure it at standard and ADA compliant height requirements.

Ends of adjoining countertops and cabinets shall be flush and considered finished ends.

NOTE: These drawings are available as Autodesk® Revit® Families and AutoCAD® ".DWG" and ".DXF" files at <http://www.woodworkinstitute.com/manual.asp> or with our CD Rom version of the **MANUAL**.

100 SERIES, BASE CABINETS w/o DRAWERS

(Continued)

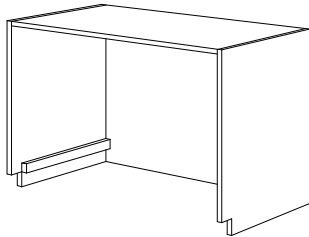

160
Cart Storage
Hardwood Side Guides

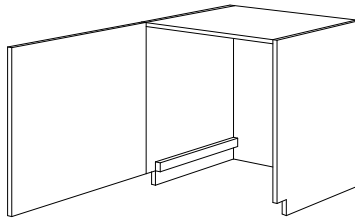

161
Cart Storage
Hardwood Side Guides

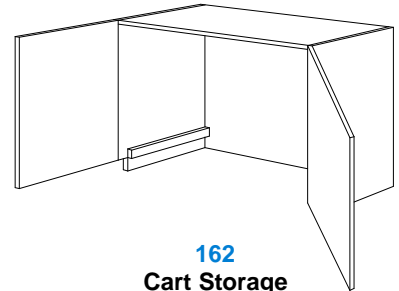

162
Cart Storage
Hardwood Side Guides

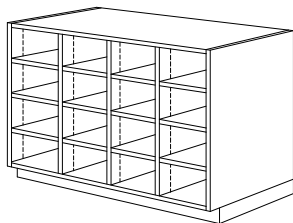

170
Open

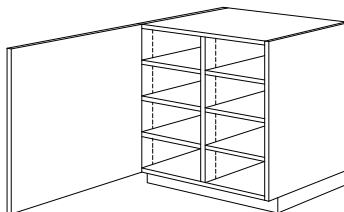

171

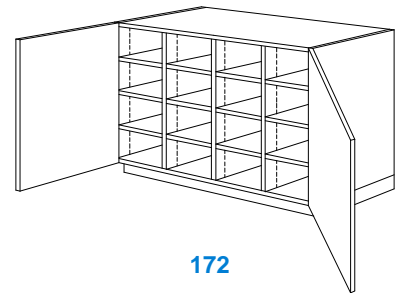

172

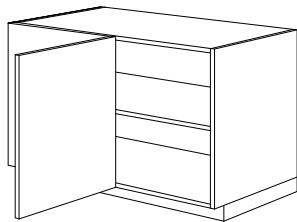

176
Blind Corner

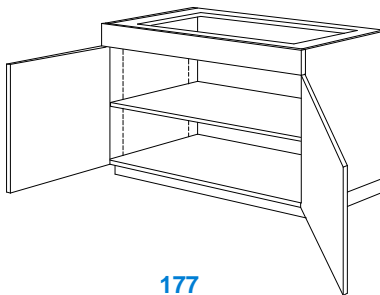

177

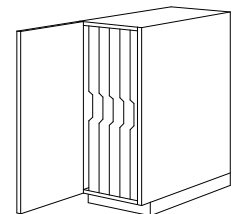

178
Range Tray Storage
1/4" Dividers

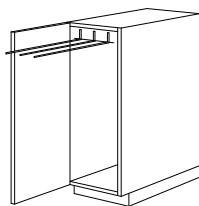

179
Retractable Towel Rack

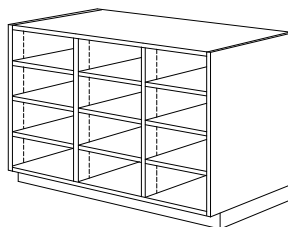

180
Open

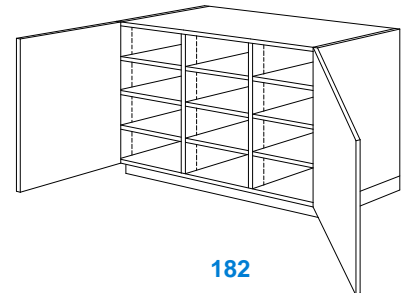

182

NOTE: These drawings are available as **Autodesk® Revit®** Families and **AutoCAD® “.DWG”** and **“.DXF”** files at <http://www.woodworkinstitute.com/manual.asp> or with our CD Rom version of the **MANUAL**.

100 SERIES, BASE CABINETS w/o DRAWERS

(Continued)

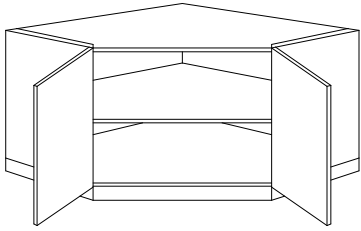

186
Corner

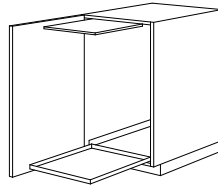

187
Sliding Tray &
Lift Up Shelf

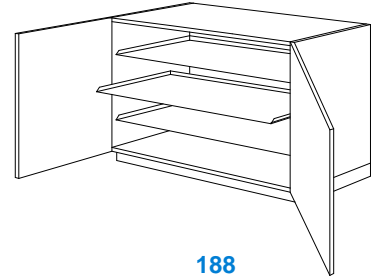

188
Sliding Trays

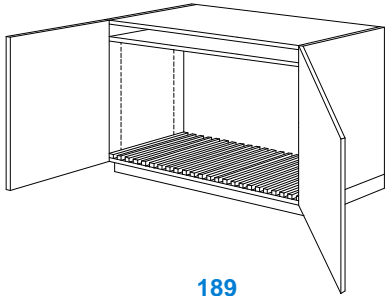

189
Drawing Board Rack

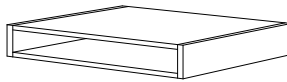

190
Storage Apron

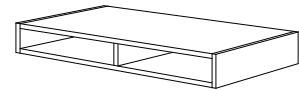

191
Storage Apron

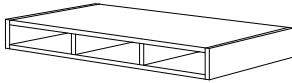

192
Storage Apron

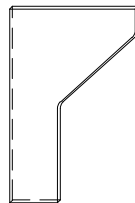

193
Countertop Support
Floor & Wall Mounted

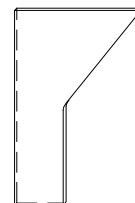

194
Countertop Support
Floor & Wall Mounted

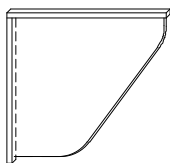

195
Countertop Support
Wall Mounted

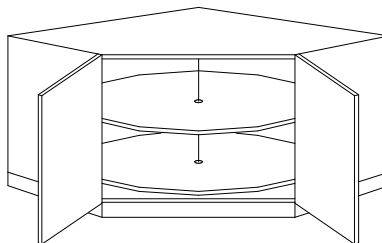

196
Corner / Lazy Susan

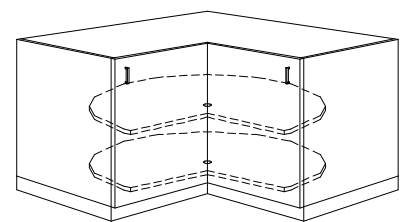

197
Corner / Lazy Susan

NOTE: These drawings are available as **Autodesk® Revit®** Families and **AutoCAD® “.DWG”** and **“.DXF”** files at <http://www.woodworkinstitute.com/manual.asp> or with our CD Rom version of the **MANUAL**.

100 SERIES, BASE CABINETS w/o DRAWERS

(Continued)

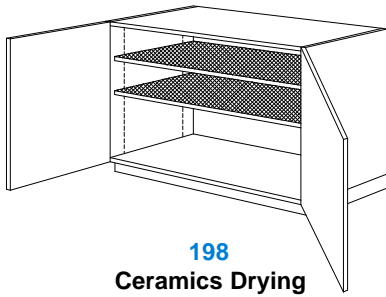

198

Ceramics Drying

Includes Adjustable Metal Frame
Shelves w/ Galvanized Wire Mesh

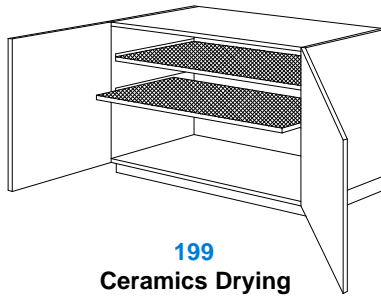

199

Ceramics Drying

Includes Sliding Metal Frame
Shelves w/ Galvanized Wire Mesh

NOTES

NOTE: These drawings are available as **Autodesk® Revit®** Families and **AutoCAD® “.DWG”** and **“.DXF”** files at <http://www.woodworkinstitute.com/manual.asp> or with our CD Rom version of the **MANUAL**.

200 SERIES, BASE CABINETS with DRAWERS

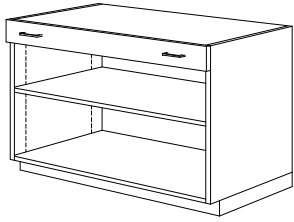

210
Open, Single Drawer

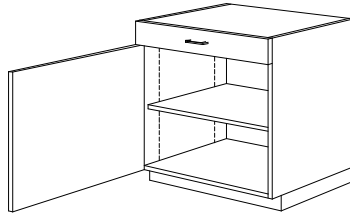

211

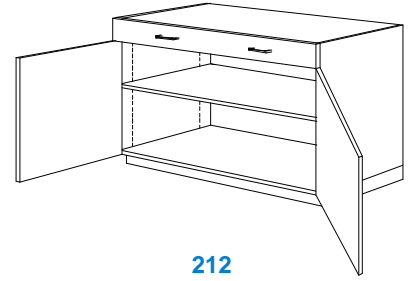

212
Single Drawer

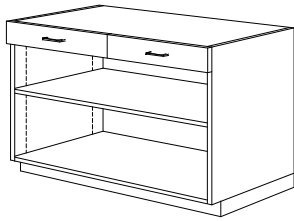

220
Open, Two Drawers

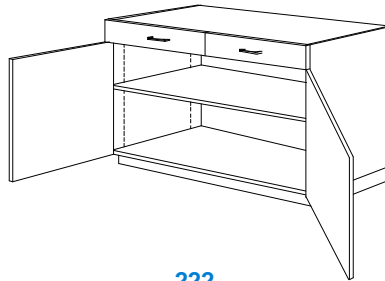

222
Two Drawers

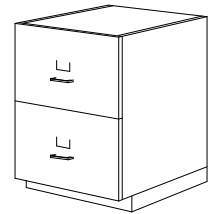

223
File Drawers w/ Full
Extension Slides and File
Follower or Hanging System

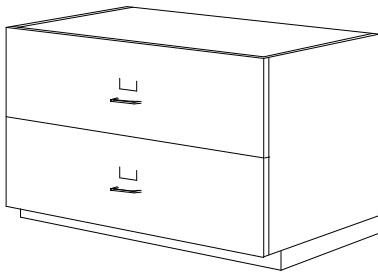

224
File Drawers w/ Full
Extension Slides and File
Follower or Hanging System

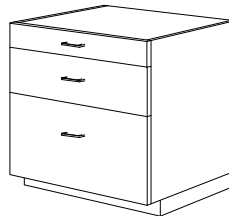

230
File Drawers w/ Full
Extension Slides and File
Follower or Hanging System

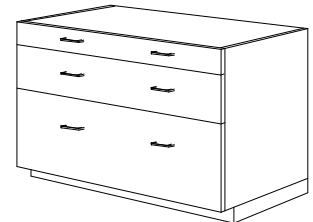

231
File Drawers w/ Full
Extension Slides and File
Follower or Hanging System

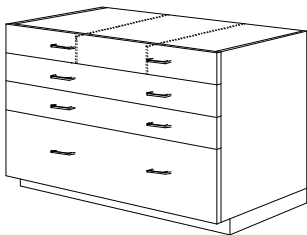

240
Top Drawer Divided into Three
Equal Spaces Left to Right

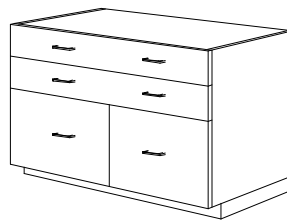

242
File Drawers w/ Full
Extension Slides and File
Follower or Hanging System

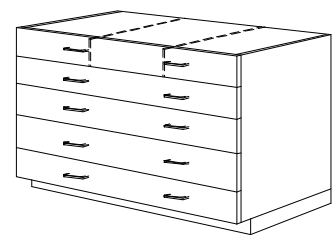

250
Top Drawer Divided into Three
Equal Spaces Left to Right

NOTE: These drawings are available as **Autodesk® Revit®** Families and **AutoCAD® “.DWG”** and **“.DXF”** files at <http://www.woodworkinstitute.com/manual.asp> or with our CD Rom version of the **MANUAL**.

200 SERIES, BASE CABINETS with DRAWERS

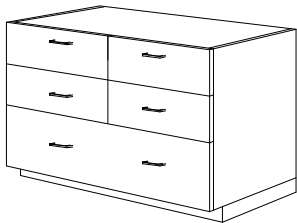

251

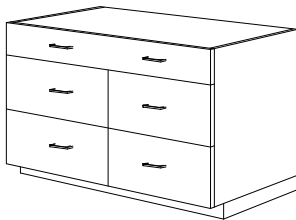

252

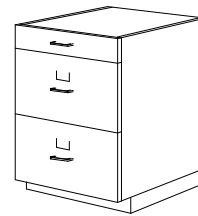

253

File Drawers w/ Full Extension Slides and File Follower or Hanging System



254

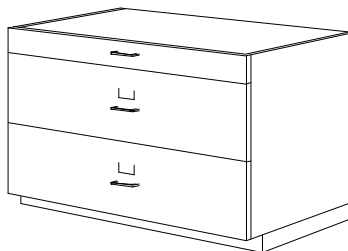

255

File Drawers w/ Full Extension Slides and File Follower or Hanging System

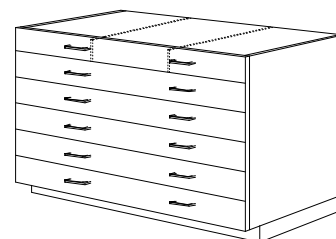

260

Top Drawer Divided into Three Equal Spaces Left to Right

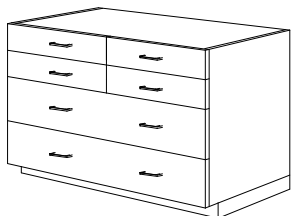

261

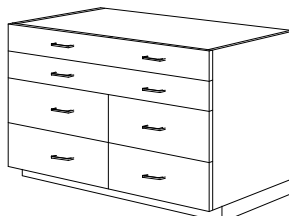

262

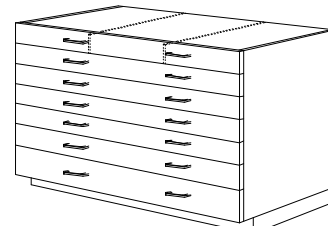

270

Top Drawer Divided into Three Equal Spaces Left to Right

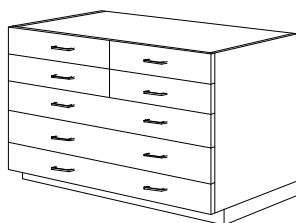

271



272

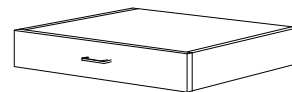

290

Drawer Apron

NOTE: These drawings are available as **Autodesk® Revit®** Families and **AutoCAD® “.DWG”** and **“.DXF”** files at <http://www.woodworkinstitute.com/manual.asp> or with our CD Rom version of the **MANUAL**.

200 SERIES, BASE CABINETS with DRAWERS (Continued)

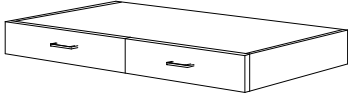

291
Drawer Apron

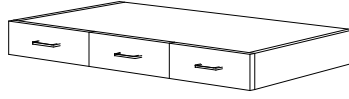

292
Drawer Apron

NOTES

NOTE: These drawings are available as **Autodesk® Revit®** Families and **AutoCAD® .DWG** and **.DXF** files at <http://www.woodworkinstitute.com/manual.asp> or with our CD Rom version of the **MANUAL**.

300 SERIES, WALL HUNG CABINET

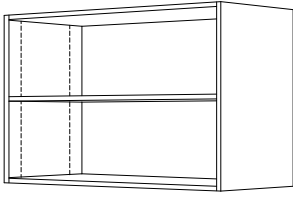

300
Open

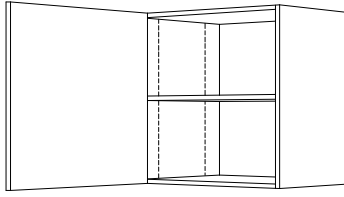

301

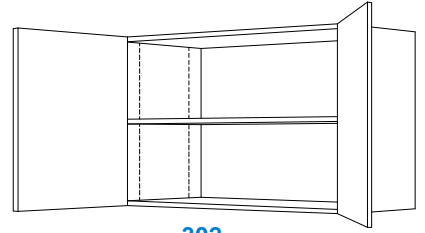

302

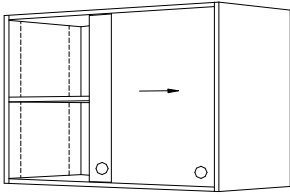

306
3/4" Sliding Doors

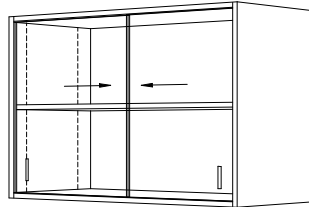

307
1/4" Glass Sliding Doors

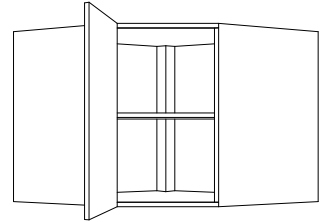

308
Angle Corner

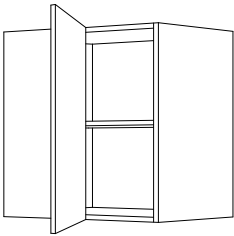

309
Blind Corner

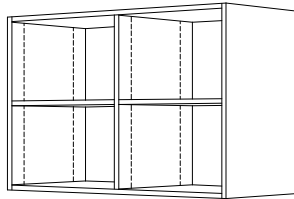

310
Open

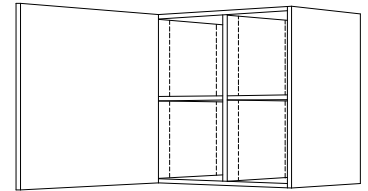

311

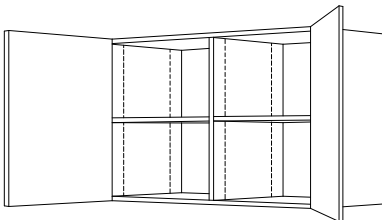

312

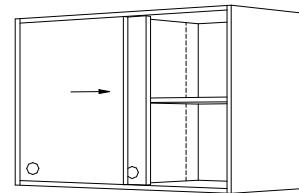

316
3/4" Sliding Doors

NOTE: These drawings are available as **Autodesk Revit** Families and **AutoCAD ".DWG"** and **".DXF"** files at <http://www.woodworkinstitute.com/manual.asp> or with our CD Rom version of the **MANUAL**.

300 SERIES, WALL HUNG CABINET

(Continued)

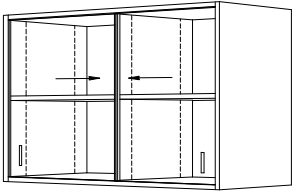

317
1/4" Glass Sliding Doors

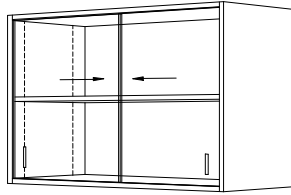

318
1/4" Glass Sliding Doors &
1/4" Glass Back w/ Removable Stops

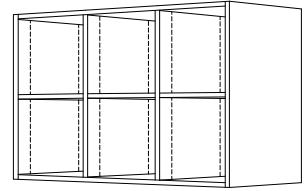

320
Open

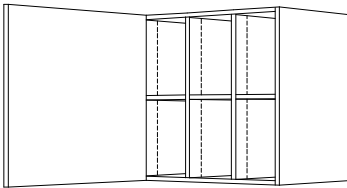

321

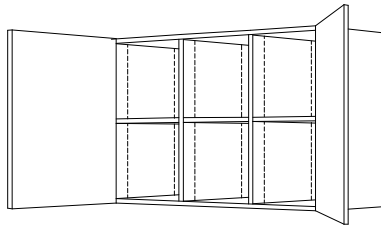

322

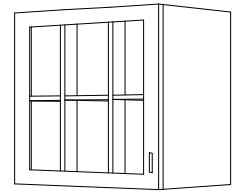

323
3/4" Glass S & R Door

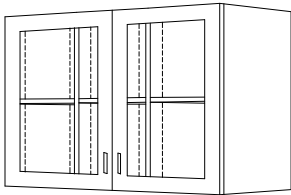

324
3/4" Glass S & R Doors

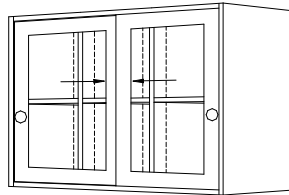

325
3/4" Sliding Glass S & R Doors

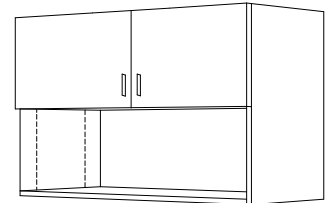

326
Partial Open

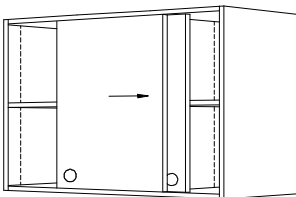

336
3/4" Sliding Doors

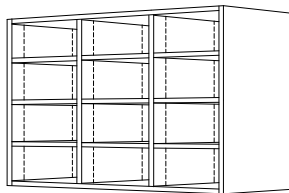

340
Cubicles

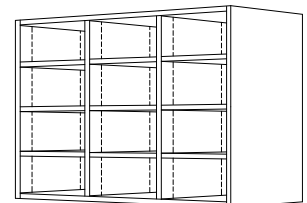

341
Cubicles
(Open back)

NOTE: These drawings are available as **Autodesk® Revit®** Families and **AutoCAD® “.DWG”** and **“.DXF”** files at <http://www.woodworkinstitute.com/manual.asp> or with our CD Rom version of the **MANUAL**.

300 SERIES, WALL HUNG CABINET

(Continued)

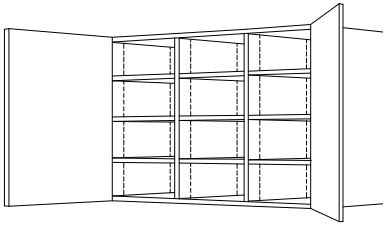

342
Cubicles

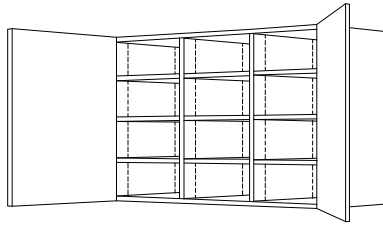

343
Cubicles
(Open back)

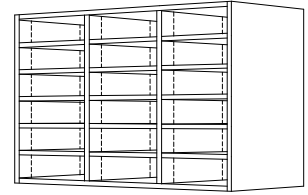

350
Mail Boxes w/
1/4" Shelves

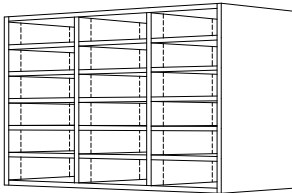

351
Mail Boxes w/
1/4" Shelves
(Open back)

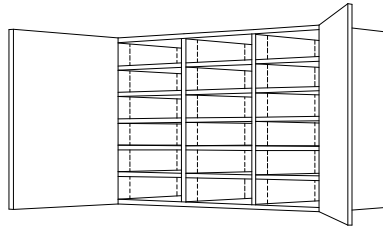

352
Mail Boxes w/
1/4" Shelves

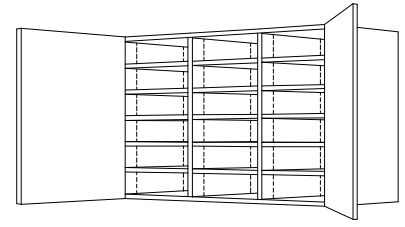

353
Mail Boxes w/
1/4" Shelves
(Open back)

NOTE: These drawings are available as **Autodesk® Revit®** Families and **AutoCAD® .DWG** and **.DXF** files at <http://www.woodworkinstitute.com/manual.asp> or with our CD Rom version of the **MANUAL**.

400 SERIES, TALL STORAGE CABINETS

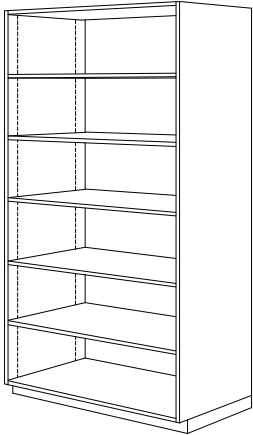

400

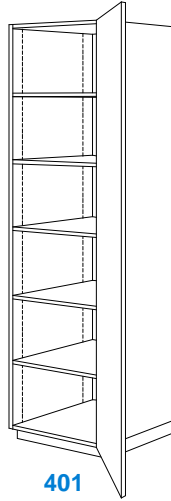

401

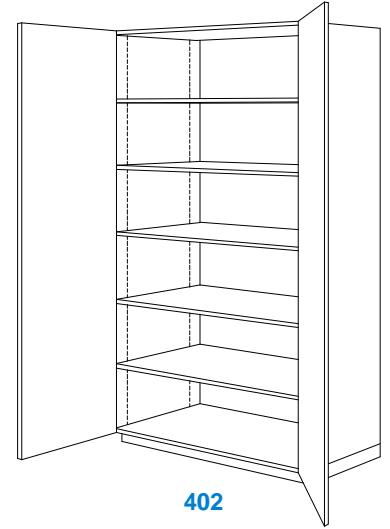

402

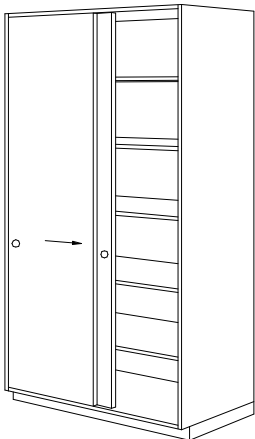

406
3/4" Sliding Doors

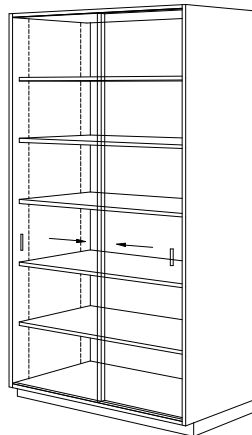

407
1/4" Sliding Glass Doors

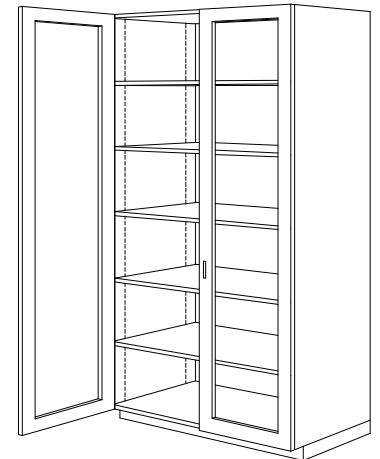

408
3/4" S & R Glass Doors

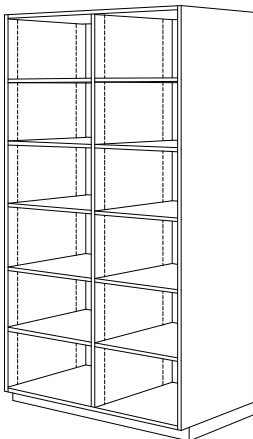

410

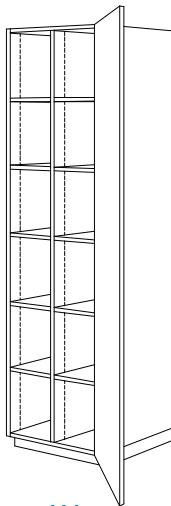

411

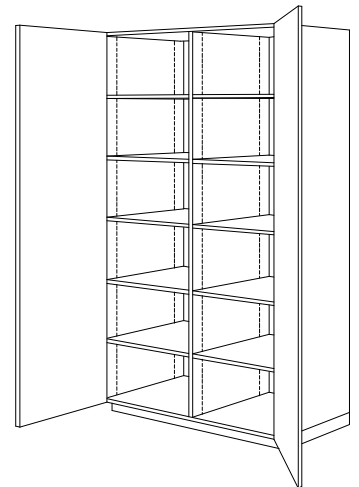

412

NOTE: These drawings are available as **Autodesk® Revit®** Families and **AutoCAD® “.DWG”** and **“.DXF”** files at <http://www.woodworkinstitute.com/manual.asp> or with our CD Rom version of the **MANUAL**.

400 SERIES, TALL STORAGE CABINETS

(Continued)

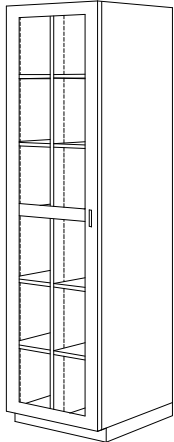

413

3/4" S & R Glass Doors

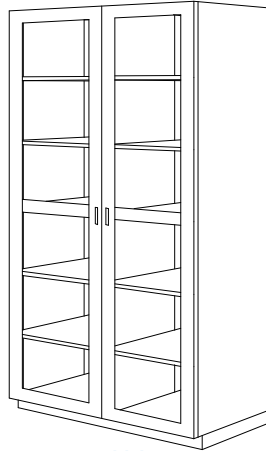

414

3/4" S & R Glass Doors

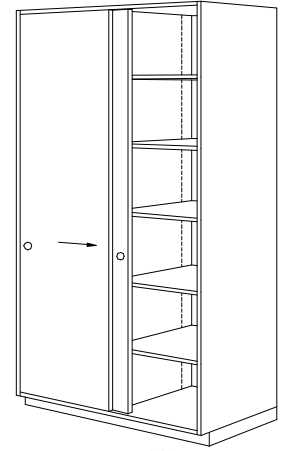

416

3/4" Sliding Doors

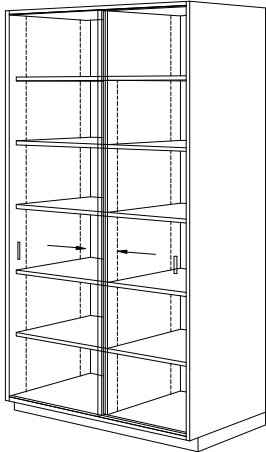

417

1/4" Sliding Glass Doors

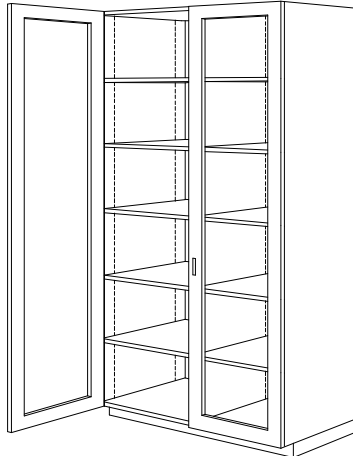

418

3/4" S & R Glass Doors

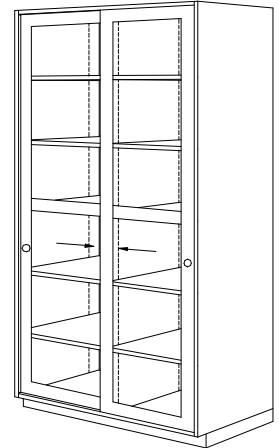

419

3/4" Sliding
S & R Glass Doors

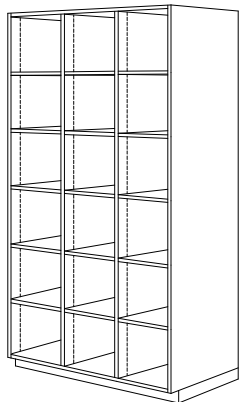

420

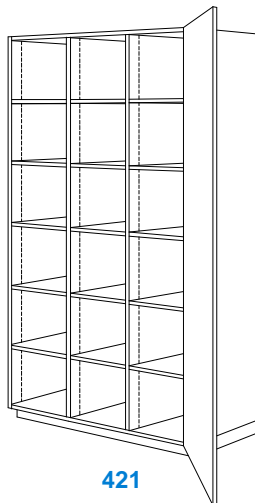

421

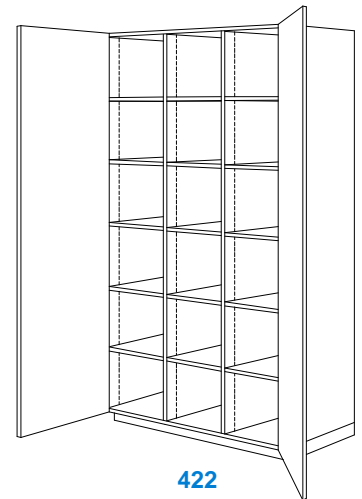

422

NOTE: These drawings are available as **Autodesk® Revit®** Families and **AutoCAD® “.DWG”** and **“.DXF”** files at <http://www.woodworkinstitute.com/manual.asp> or with our CD Rom version of the **MANUAL**.

400 SERIES, TALL STORAGE CABINETS

(Continued)

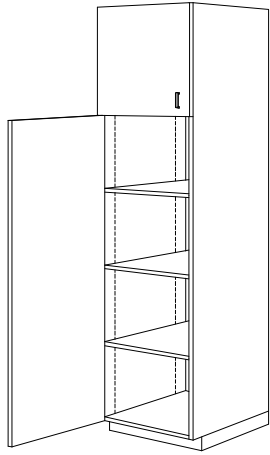

423
Split Height

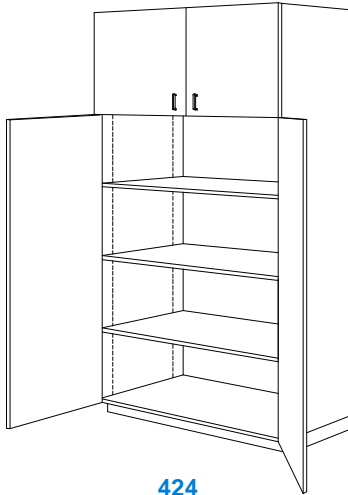

424
Split Height

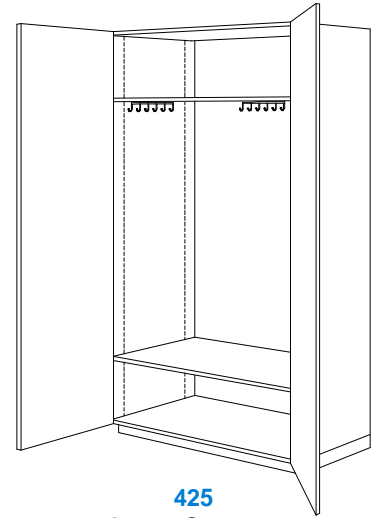

425
Apron Storage
Pull Out Hooks

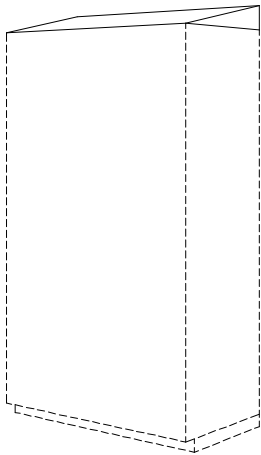

426
Dust Panel
Integral or Separate

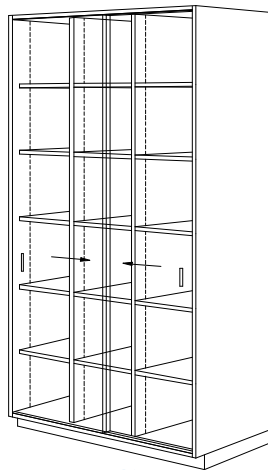

427
1/4" Sliding Glass Doors

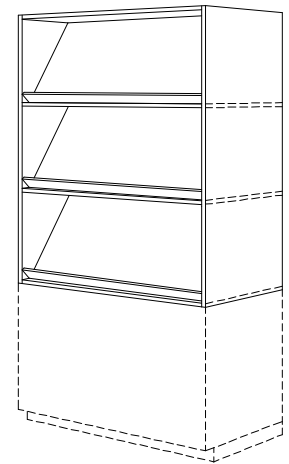

429
Display Hutch w/
Fixed Angled Shelves

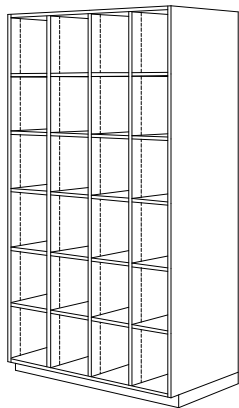

430

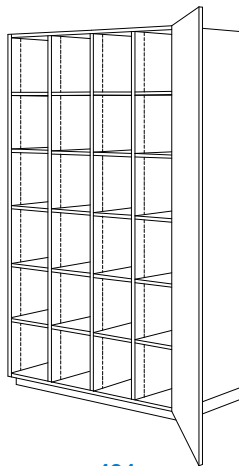

431

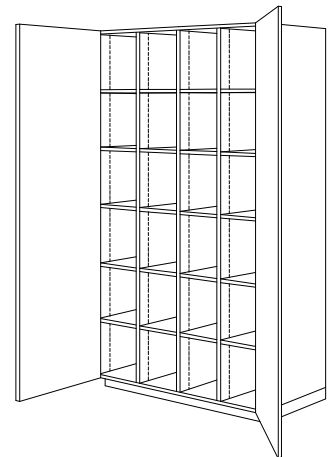

432

NOTE: These drawings are available as **Autodesk® Revit®** Families and **AutoCAD® “.DWG”** and **“.DXF”** files at <http://www.woodworkinstitute.com/manual.asp> or with our CD Rom version of the **MANUAL**.

400 SERIES, TALL STORAGE CABINETS

(Continued)

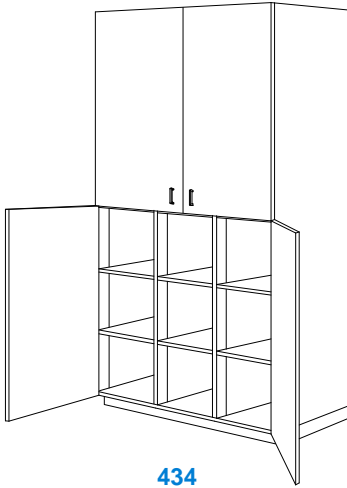

434
Split Height

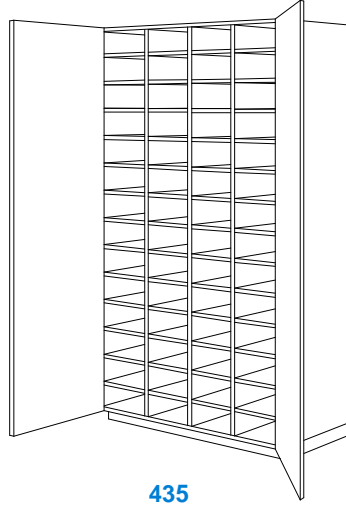

435
Holds 56 Tote Trays
However Tote Trays are NIC

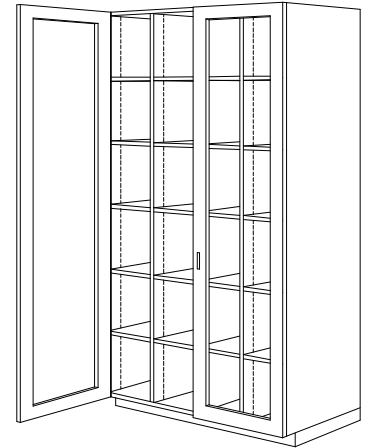

438
3/4" S & R Glass Doors

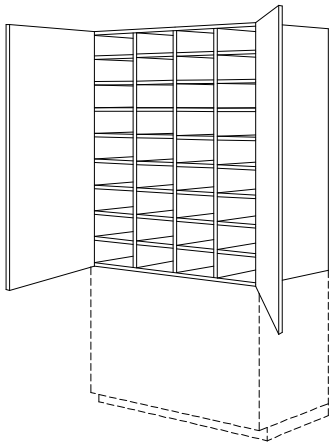

439
Hutch, holds 32 Tote Trays
Tote Trays are NIC

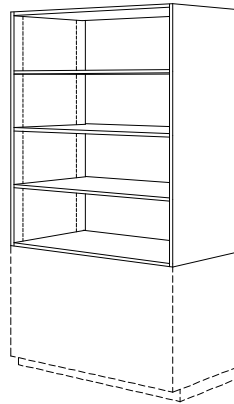

440
Open Hutch

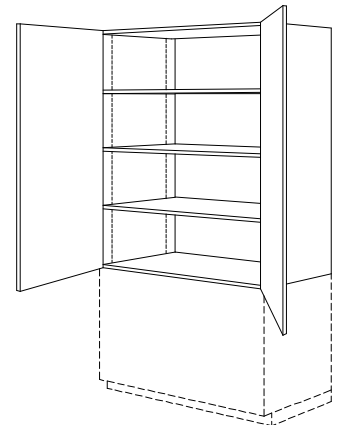

441
Hutch

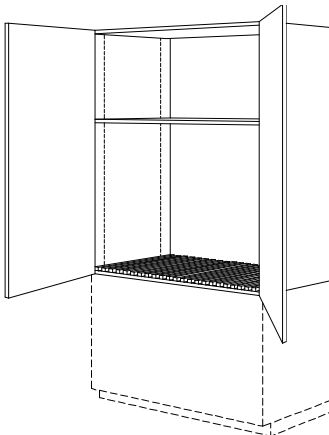

443
Hutch Drawing Board Storage

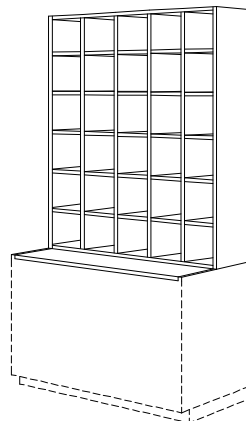

444
Hutch w/ Open Cubicles

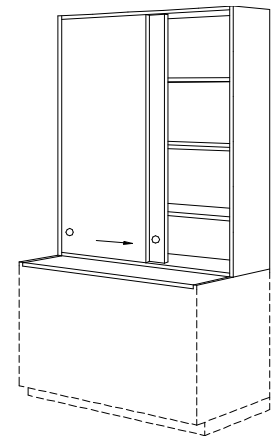

445
Hutch w/ 3/4" Sliding Doors

NOTE: These drawings are available as **Autodesk® Revit®** Families and **AutoCAD® “.DWG”** and **“.DXF”** files at <http://www.woodworkinstitute.com/manual.asp> or with our CD Rom version of the **MANUAL**.

400 SERIES, TALL STORAGE CABINETS

(Continued)

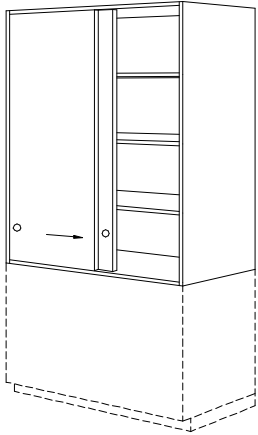

446
Hutch
3/4" Sliding Doors

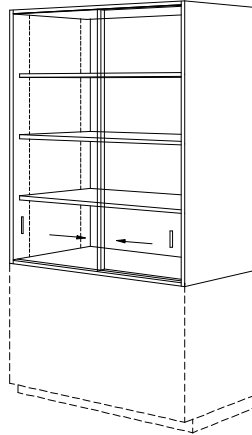

447
Hutch
1/4" Sliding Glass Doors

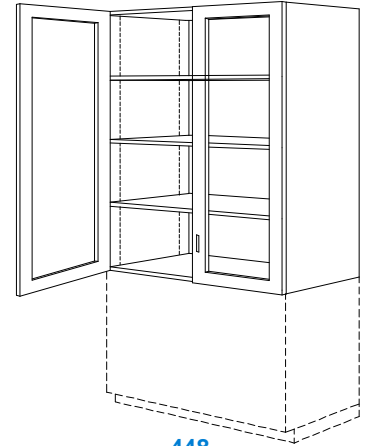

448
Hutch
3/4" S & R Glass Doors

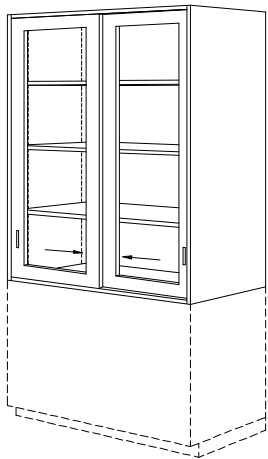

449
Hutch
3/4" S & R Sliding Glass Doors

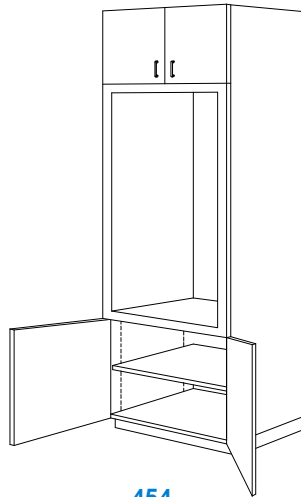

454
Oven Cabinet

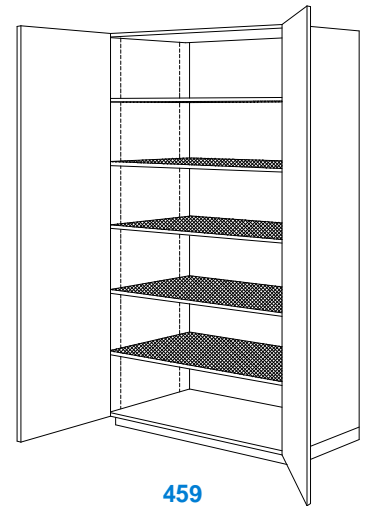

459
Ceramic Drying Storage
Adjustable Metal Frame
W/ Galvanized Wire Mesh

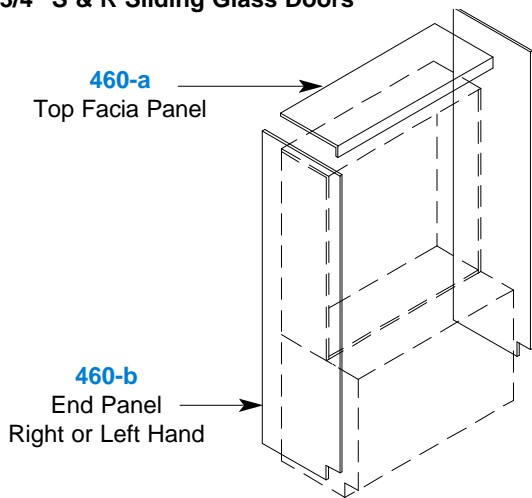

460 Presentation Panel Surrounds

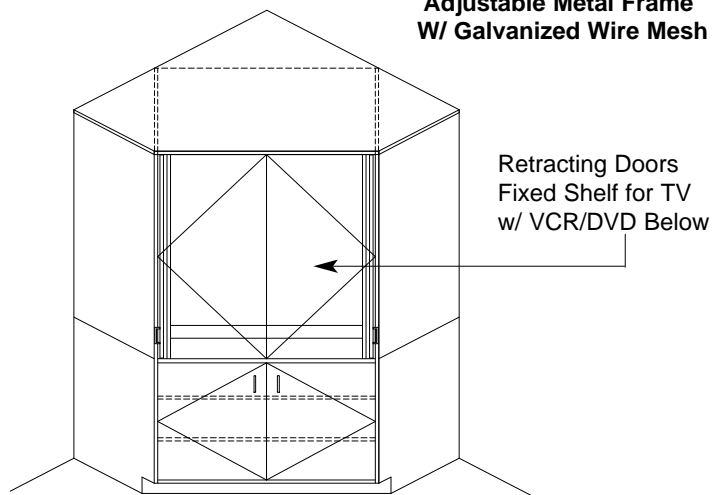

461 Audio Visual Center

NOTE: These drawings are available as **Autodesk® Revit®** Families and **AutoCAD® “.DWG”** and **“.DXF”** files at <http://www.woodworkinstitute.com/manual.asp> or with our CD Rom version of the **MANUAL**.

500 SERIES, WARDROBE CABINETS

MIRRORS TO BE FRAMED 12" X 14" X 1/4" PLATE, WITH PIN TRAY

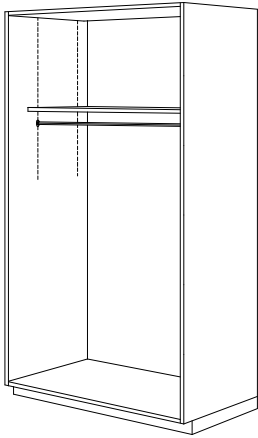

500
Open Wardrobe
Shelf & Pole

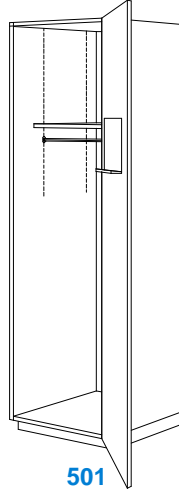

501
Teachers Wardrobe w/
Lock, Shelf, Pole & Mirror

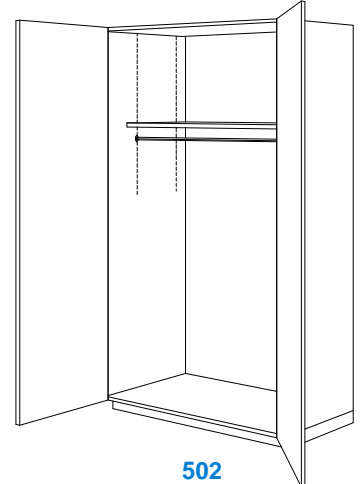

502
Student Wardrobe
Shelf & Pole

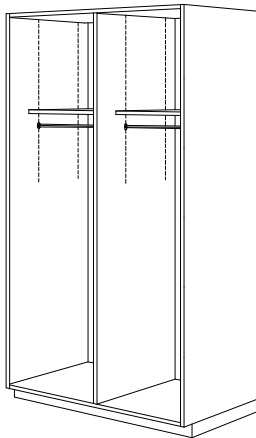

510
Open Wardrobe
Shelf & Pole

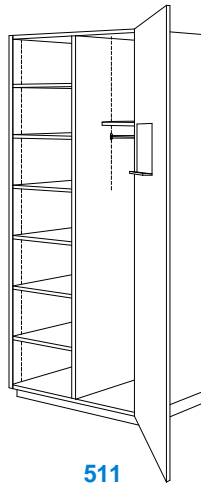

511
Split Unit, Shelves / Wardrobe
w/ Shelf, Pole, Mirror & Lock

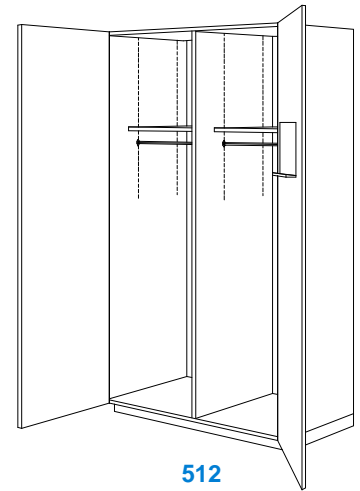

512
Dual Wardrobe
Shelf, Pole, Mirror & Lock

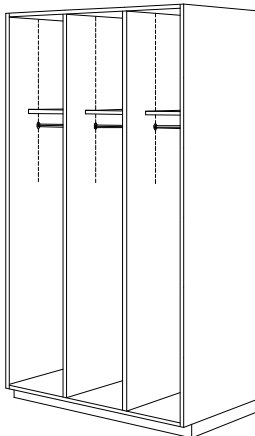

520
Triple Open Wardrobe
Shelf & Pole

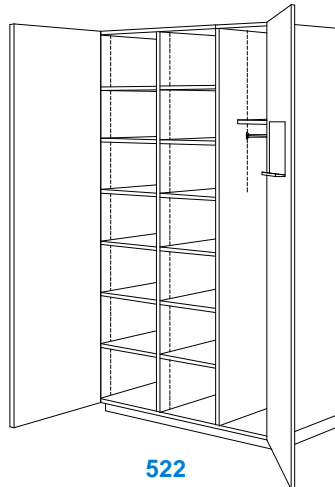

522
Wardrobe & Cubicles
Shelves, Pole, Mirror & Lock

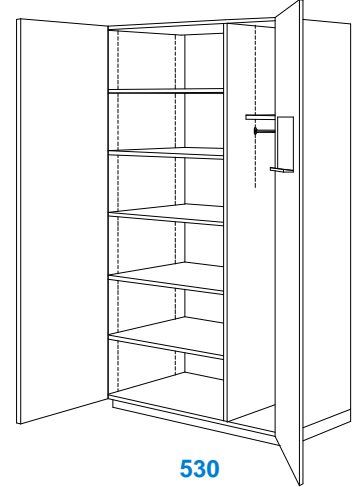

530
Wardrobe & Shelving
Shelves, Pole, Mirror & Lock

NOTE: These drawings are available as **Autodesk® Revit®** Families and **AutoCAD® “.DWG”** and **“.DXF”** files at <http://www.woodworkinstitute.com/manual.asp> or with our CD Rom version of the **MANUAL**.

500 SERIES, WARDROBE CABINETS

(Continued)

MIRRORS TO BE FRAMED 12" X 14" X 1/4" PLATE, WITH PIN TRAY

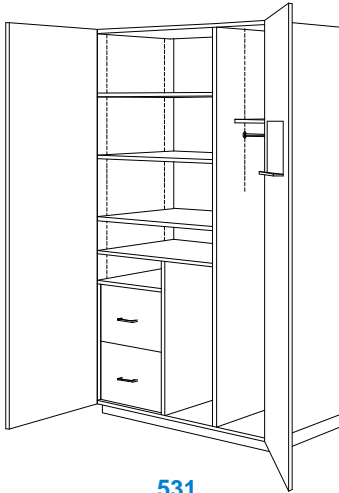

531

Teacher Center w/ Lock Shelves, Pole & Mirror
2 Legal File Drawers

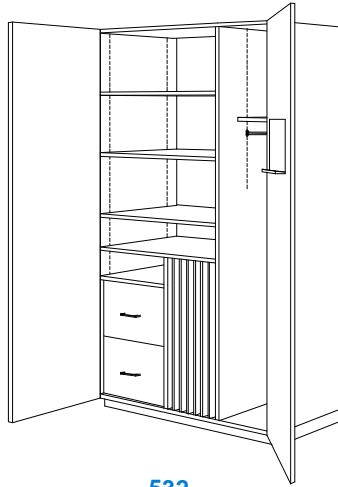

532

Teacher Center w/ Lock Shelves, Pole & Mirror
2 Legal File Drawers & 1/4" Dividers

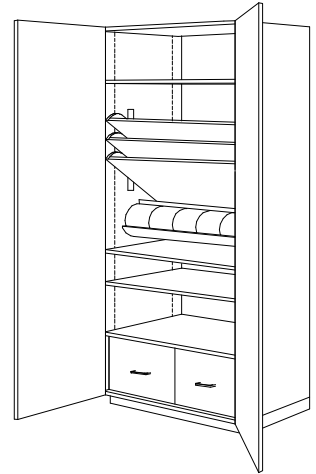

533

Teacher Center w/ Lock, Slide Out Tilting Paper Shelves*, Paper Roller & 2 Legal File Drawers

NOTE: Drawers in cabinets 531-533 shall be spaced away from cabinet ends up to 1" to allow for proper functionality when doors are in the ninety degree open position.

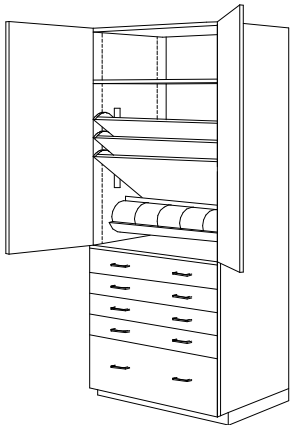

534

Teacher Center w/ Lock, Slide Out Tilting Paper Shelves*, Paper Roller & Misc. Drawers



540

Hanging Wardrobe Shelf & Pole

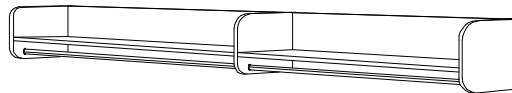

541

Double Hanging Wardrobe Shelf & Pole

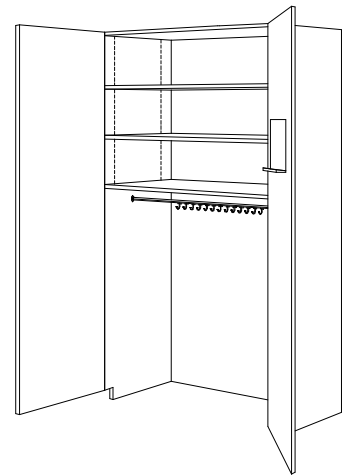

552

Student Wardrobe w/ 15 Wall Hooks, Shelves, Ceiling Hooks or Pole

* See Slide Out Tilting Paper Shelf details on next page in this Supplement 2

NOTE: These drawings are available as **Autodesk® Revit®** Families and **AutoCAD® .DWG** and **.DXF** files at <http://www.woodworkinstitute.com/manual.asp> or with our CD Rom version of the **MANUAL**.

TYPICAL SLIDE OUT/TILTING PAPER SHELF DETAILS

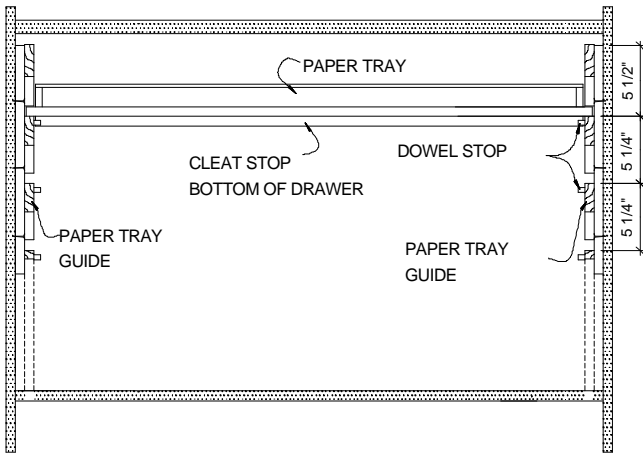

**Paper Tray Guide System
Front View**

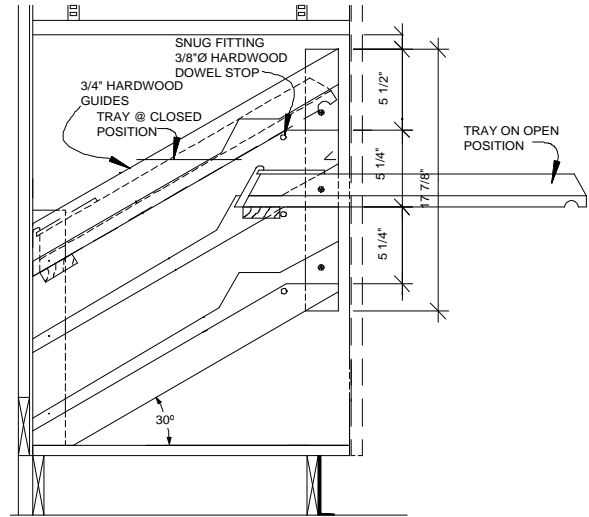

**Paper Tray Guide System
Side View**

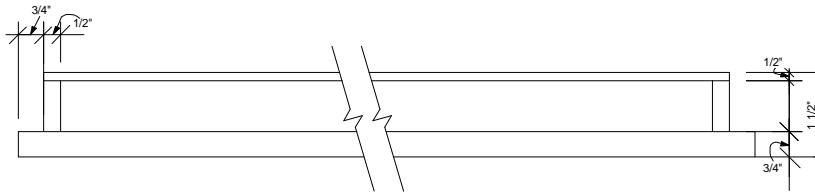

Paper Tray - Front View

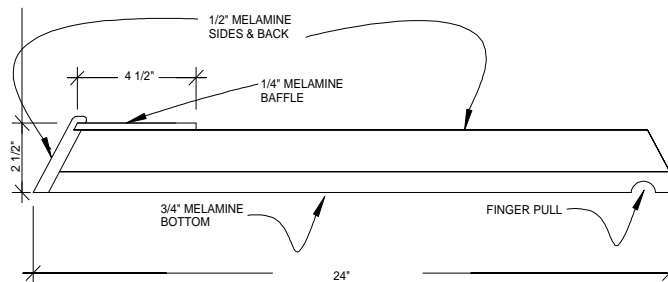

Paper Tray - Side View

NOTE: These drawings are available as **Autodesk® Revit®** Families and **AutoCAD® .DWG** and **.DXF** files at <http://www.woodworkinstitute.com/manual.asp> or with our CD Rom version of the **MANUAL**.

600 SERIES, LIBRARY CABINETS
 SEE PAGE 21 OF THIS SUPPLEMENT FOR 600 SERIES NOTES



600 w/ or 605 w/o Back
 42" in Height including Top



601 w/ or 606 w/o Back
 60-1/2" Height including Top
 Side View

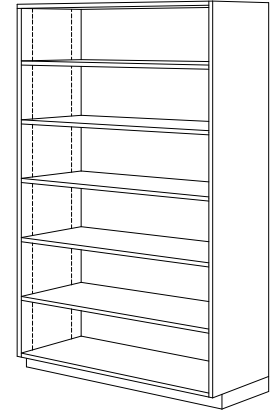

602 w/ or 607 w/o Back
 72", 80" or 84" Height

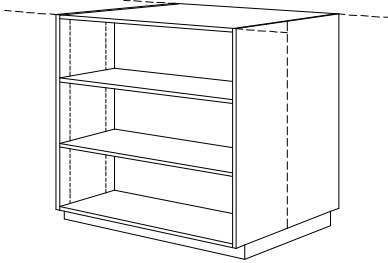

620 w/ or 625 w/o Back
 42" in Height including Top
 Back Same as Front

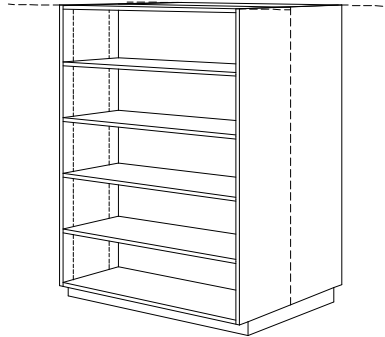

621 w/ or 626 w/o Back
 60-1/2" Height including Top
 Back Same as Front

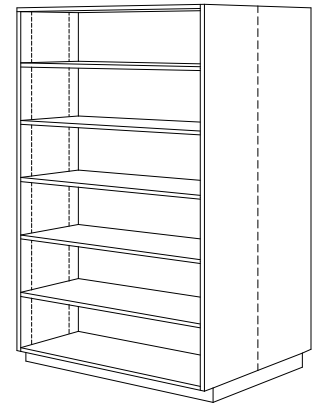

622 w/ or 627 w/o Back
 72", 80" or 84" Height
 Back Same as Front

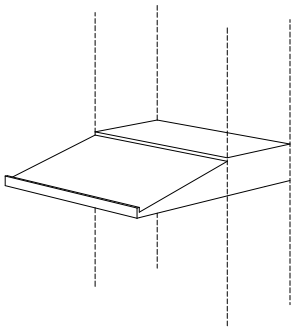

614
 Library of Congress Shelf

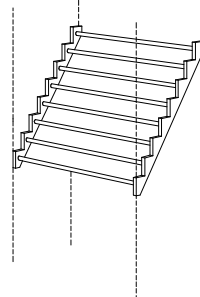

624
 Newspaper Rack
 Hardwood Dowels

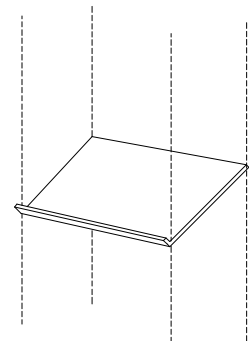

634
 Display Shelf

UNITS 614, 624 and 634 ARE INSERTS FOR THE ABOVE BOOK CASES

NOTE: These drawings are available as **Autodesk® Revit®** Families and **AutoCAD® ".DWG"** and **".DXF"** files at <http://www.woodworkinstitute.com/manual.asp> or with our CD Rom version of the **MANUAL**.

600 SERIES, LIBRARY CABINETS

(Continued)

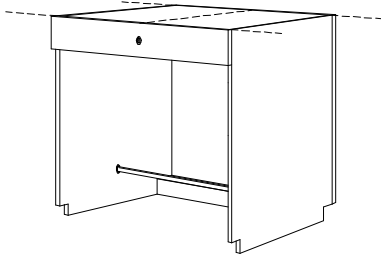

640

**Charge Desk w/ Foot Rest,
Locked & Divided Top Drawer
w/ Cash Tray**

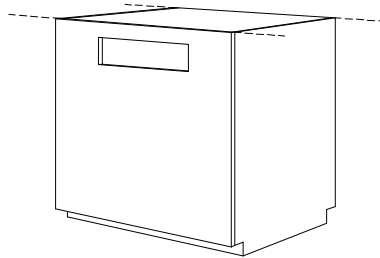

641

Book Return

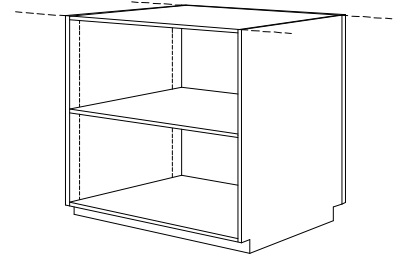

644

Open Base

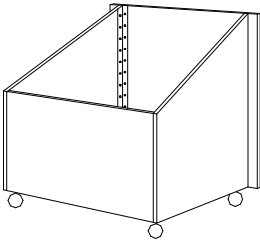

651

**Book Cart, Fits 641
w/ Casters**

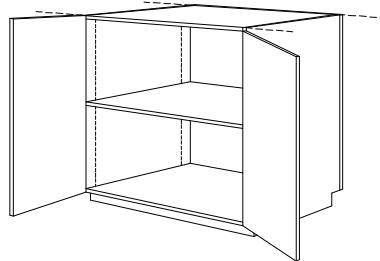

654

Base w/ Doors

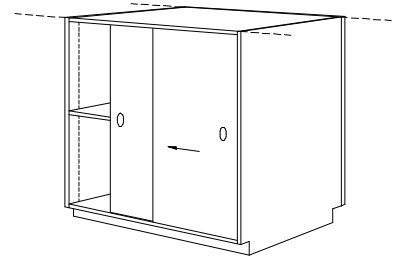

664

Base w/ 3/4" Sliding Doors

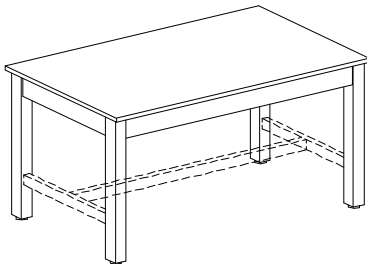

**671-a w/o Lateral Bracing
671-b w/ Lateral Bracing
Table**

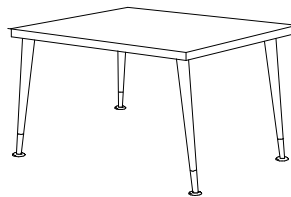

672

Table

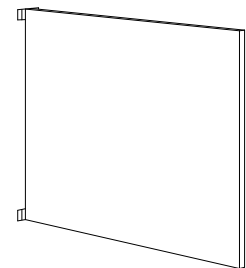

673

Gate

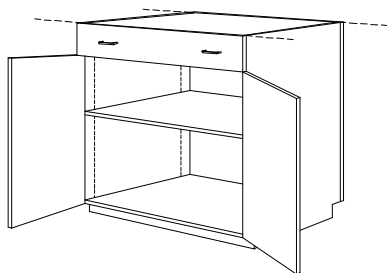

674

Base w/ Drawer

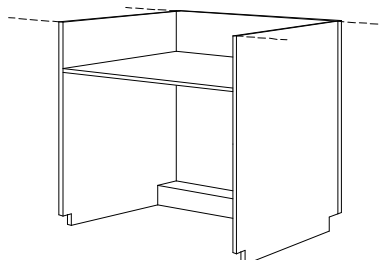

681

Desk

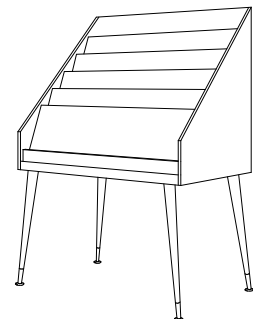

**682 or 692 w/ 18" Legs
Magazine Rack**

NOTE: These drawings are available as **Autodesk® Revit®** Families and **AutoCAD® “.DWG”** and **“.DXF”** files at <http://www.woodworkinstitute.com/manual.asp> or with our CD Rom version of the **MANUAL**.

600 SERIES, LIBRARY CABINETS

(Continued)

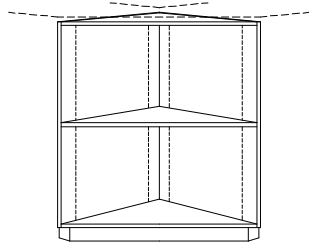

683
Corner

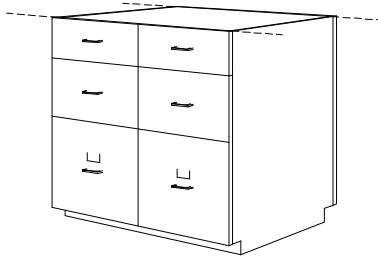

684
Base w/ File Drawers on Full Extension Slides w/ File Follower or Hanging System

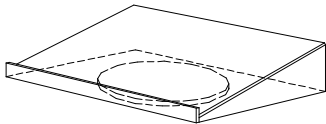

693
Dictionary Stand w/ Swivel Base

CARD FILE SYSTEM



642
Top

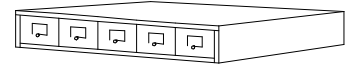

643
Card Files, 5-3/4" High

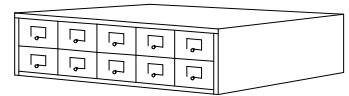

653
Card File, 10-3/4" High

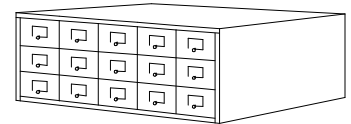

663
Card File, 15-3/4" High

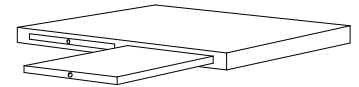

652
Slide Shelf, 2-5/8" High

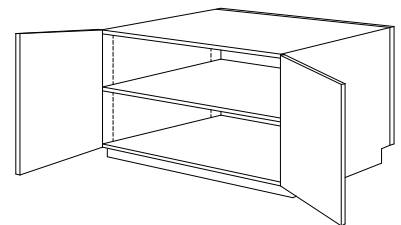

662
27" High Base for Card Files

NOTES

All Finished Backs in Panels or Continuous Lengths.
Kick Spaces Front, Back & at Exposed Ends Typical.
Card File System for 3" x 5" cards with built in follower.

NOTE: These drawings are available as **Autodesk® Revit®** Families and **AutoCAD® .DWG** and **.DXF** files at <http://www.woodworkinstitute.com/manual.asp> or with our CD Rom version of the **MANUAL**.

700 SERIES, MOVEABLE CABINETS

NOTE: All moveable units to be equipped with adequate WIC-approved casters for the intended load capacity.
SEE PAGE 1 OF THIS SUPPLEMENT FOR ADDITIONAL 700 SERIES NOTES

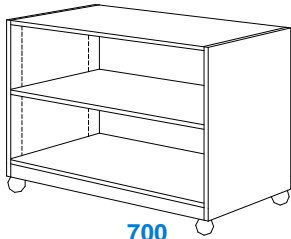

700
Open Base

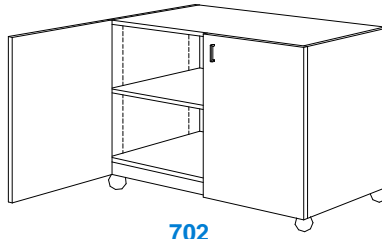

702
Base w/ Doors
Diaphragm bottom required

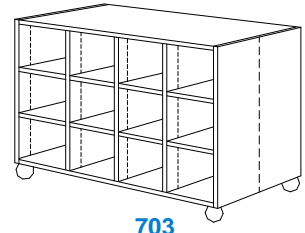

703
Base w/ Two Sides
Of Cubicles

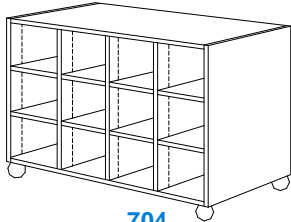

704
Base w/ One Side
of Cubicles



707
Base w/ Paper Drawers
Double Wheel Swivel Casters

Unit 707
Shall be 30" Deep w/
Top Drawer in 3 Sections
36" in Height = 6 Drawers
33" or 30" = 5 Drawers
27" or 24" = 4 Drawers

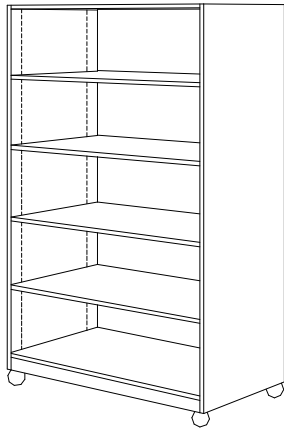

710
Open Storage



712
Storage w/ Doors
Diaphragm bottom required



714
Storage & Drawers

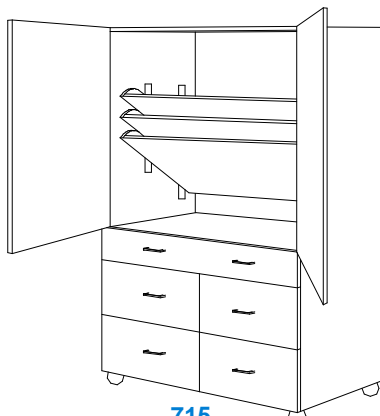

715
Storage & Drawers
Tilting Shelf details on page 298

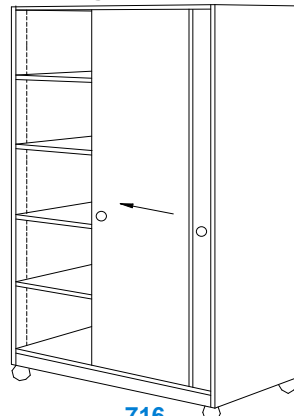

716
Storage w/ 3/4" Sliding Doors
Diaphragm bottom required

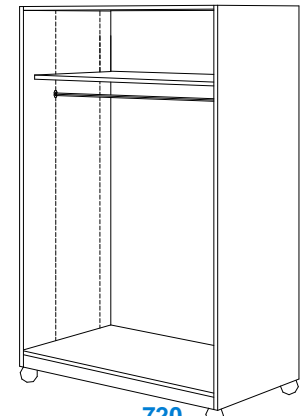

720
Open Wardrobe

NOTE: These drawings are available as Autodesk® Revit® Families and AutoCAD® “.DWG” and “.DXF” files at <http://www.woodworkinstitute.com/manual.asp> or with our CD Rom version of the **MANUAL**.

700 SERIES, MOVEABLE CABINETS

(Continued)

NOTE: All moveable units to be equipped with adequate approved casters for the intended load capacity.

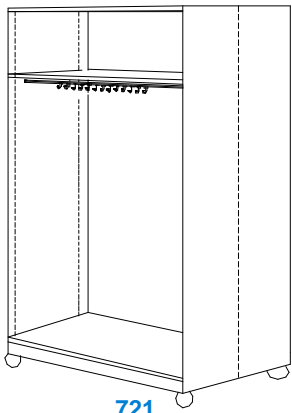

721
Open Wardrobe
Two Sides

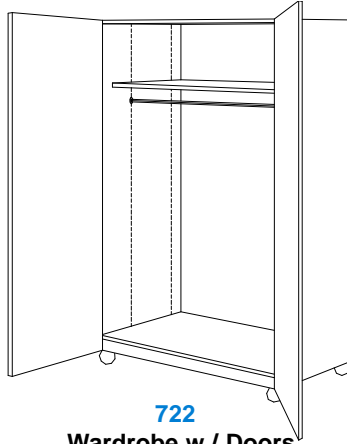

722
Wardrobe w / Doors
Diaphragm bottom required



724
Teachers Cabinet
w / File Drawers & Lock

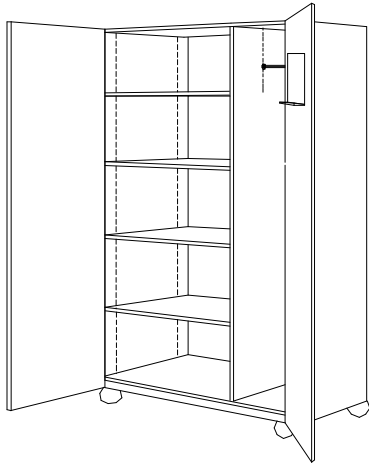

725
Teachers Cabinet
w/ Lock

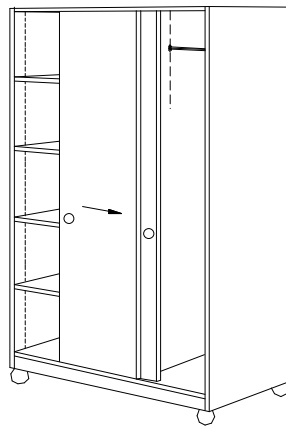

726
Teachers Cabinet
3/4" Sliding Doors & Lock

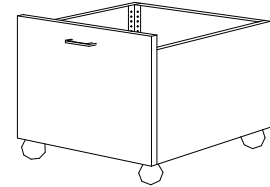

728
Toy Cart
Metal angle reinforced corners required

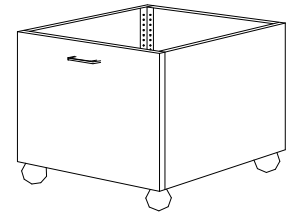

729
Toy Cart
Metal angle reinforced corners required

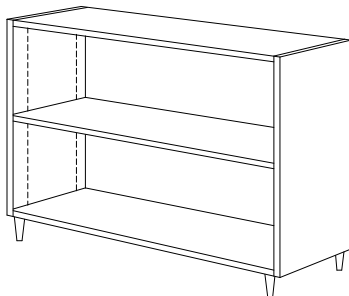

730
Bookcase, Single Sided
Fixed Tapered Legs

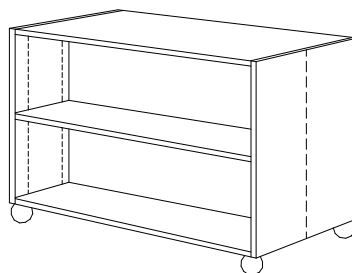

731
Bookcase, 2 Sided

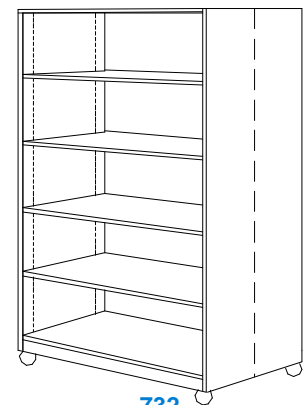

732
Bookcase, 2 Sided

NOTE: These drawings are available as **Autodesk® Revit®** Families and **AutoCAD® .DWG** and **.DXF** files at <http://www.woodworkinstitute.com/manual.asp> or with our CD Rom version of the **MANUAL**.

700 SERIES, MOVEABLE CABINETS

(Continued)

NOTE: All moveable units to be equipped with adequate approved casters for the intended load capacity.



734
Bookcase, 2 Sided

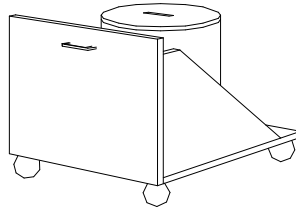

735
Clay Cart
Trash Can NIC
Metal angle reinforced corners required

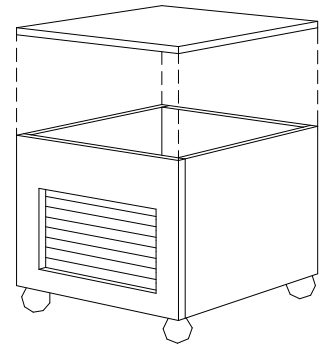

736
Clay Cart w/ Custom 22 ga.
Galvanized Liner, 3/4" LP Top
8 ea. 1/4" Hardboard Panels
Metal angle reinforced
corners required

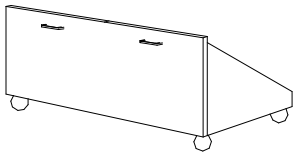

737
Block Cart
Metal angle reinforced
corners required

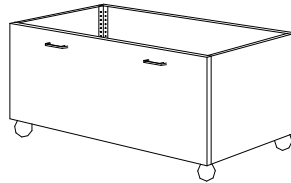

738
Block Cart
Metal angle reinforced
corners required

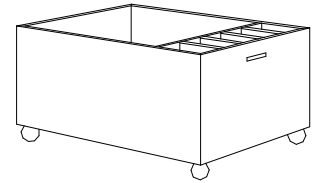

739
Ball & Bat Cart w/ 5 Equal
Compartments at One End
Metal angle reinforced
corners required

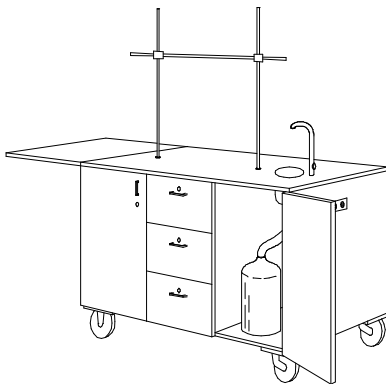

742 (See notes)
Demonstration Cart
48" x 33" x 24"
Laboratory Top

NOTES FOR CABINET 742:

To be furnished with 6" round chemical sink, Burrett Rods, cross bar and flush sockets, galley pump with polyethylene tubing and 1 gallon bottles for both fresh water and waste, 3 prong duplex outlet with 15' supply cord, locks on all doors and drawers, 6 pegs on back of storage compartment door and 1/4" pegboard liner on back of sink door.

NOTE: These drawings are available as **Autodesk® Revit®** Families and **AutoCAD® .DWG** and **.DXF** files at <http://www.woodworkinstitute.com/manual.asp> or with our CD Rom version of the **MANUAL**.

700 SERIES, MOVEABLE CABINETS

(Continued)

NOTE: All moveable units to be equipped with adequate approved casters for the intended load capacity.

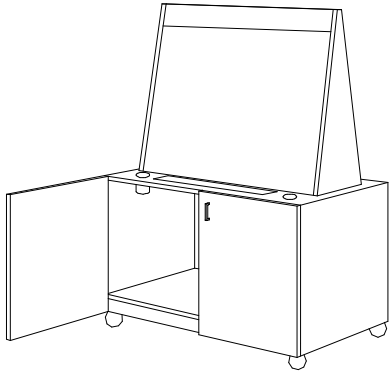

743

2 Sided Easel Cart

48" x 54" x 24"

Tack Board Top, LP Face & Top
Diaphragm bottom required

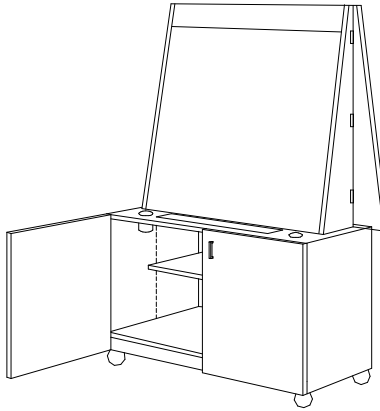

744

Single Sided Easel Cart

48" x 66" x 24" w/ Side Door

Tack Board Top, LP Face
Diaphragm bottom required

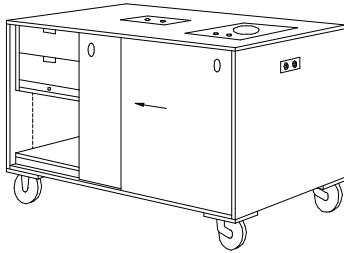

746 (See notes)

Cooking Demonstration Cart

48" x 33" x 24"

3/4" Sliding Doors & LP Top
Diaphragm bottom required

NOTES FOR CABINET 746:

To be furnished with electric cooking and mixing units,
built in 3 prong electric service w/ 15' supply cord.

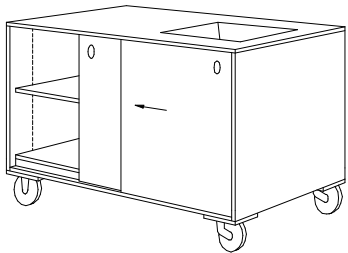

747

Nature Demonstration Cart

48" x 33" x 24"

3/4" Sliding Doors & LP Top
Removable 22ga. Galvanized Pan
Diaphragm bottom required

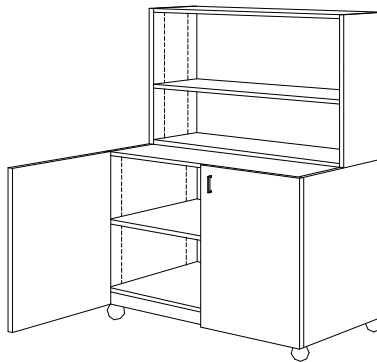

750

Open Hutch Cabinet

Diaphragm bottom required

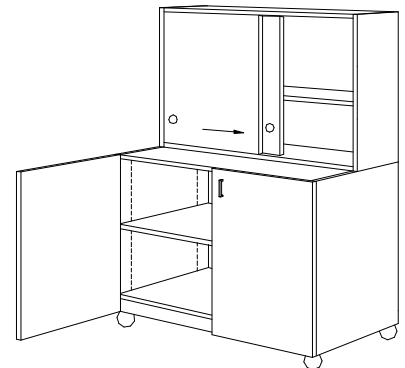

751

Hutch Cabinet

W/ 3/4" Sliding Doors
Diaphragm bottom required

NOTE: These drawings are available as **Autodesk® Revit®** Families and **AutoCAD® .DWG** and **.DXF** files at <http://www.woodworkinstitute.com/manual.asp> or with our CD Rom version of the **MANUAL**.

700 SERIES, MOVEABLE CABINETS

(Continued)

NOTE: All moveable units to be equipped with adequate approved casters for the intended load capacity.

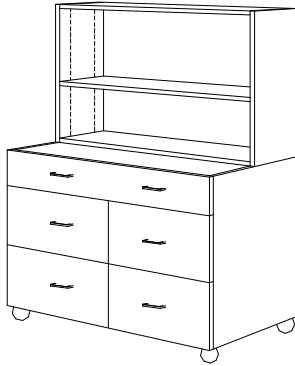

752
Open Hutch Cabinet

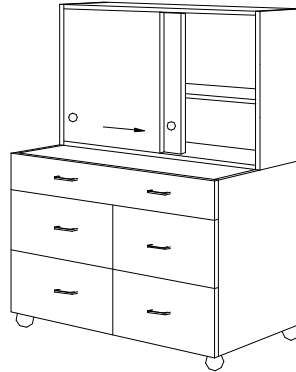

753
Hutch Cabinet
W/ 3/4" Sliding Doors



754
Open Hutch Cabinet

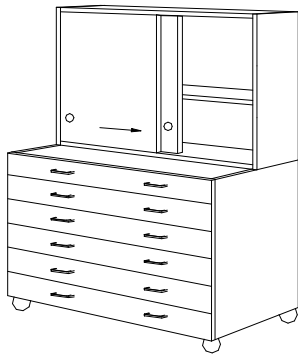

755
Hutch Cabinet
W/ 3/4" Sliding Doors

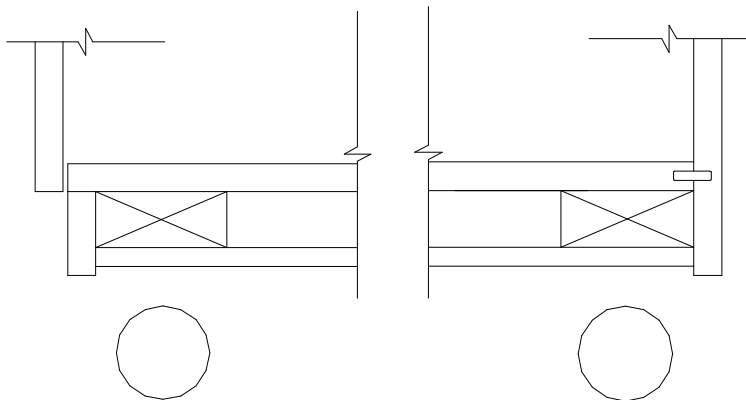

TYPICAL DIAPHRAGM BOTTOM DETAIL

NOTE: These drawings are available as **Autodesk® Revit®** Families and **AutoCAD® .DWG** and **.DXF** files at <http://www.woodworkinstitute.com/manual.asp> or with our CD Rom version of the **MANUAL**.

700 SERIES, MOVEABLE CABINETS

(Continued)

NOTE: All moveable units to be equipped with adequate approved casters for the intended load capacity.

STUDY CARRELS, LAYOUT & CONSTRUCTION

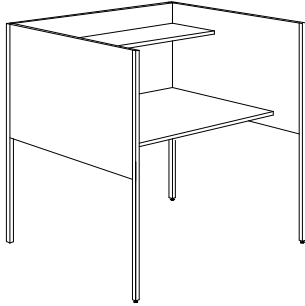

760
Study Carrel
38" x 54" x 30"

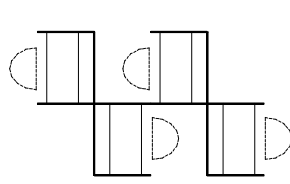

761



763

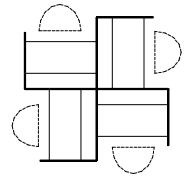

764

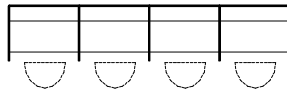

762

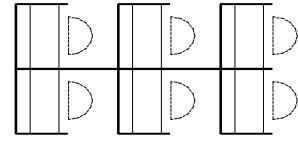

765

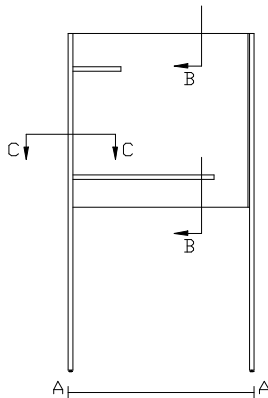

KEY

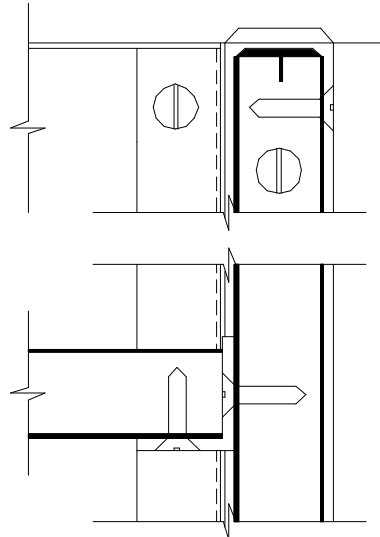

DETAIL "B"

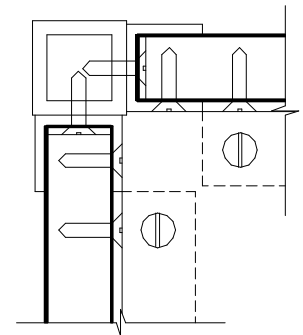

DETAIL "C"

NOTE: These drawings are available as **Autodesk Revit** Families and **AutoCAD ".DWG"** and **".DXF"** files at <http://www.woodworkinstitute.com/manual.asp> or with our CD Rom version of the **MANUAL**.

NOTES